

B. P. O. Elks
FIVE GOAL &
GRID GOAL COMPETITION

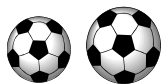

Area 1
Soccer Shoot[®]
Manual

Please Note:



The soccer ball used will be an FIFA approved ball as Follows:



Number Four (4) balls will be used for the following Groups

- Age 7 and Under [U-8]
- Age 8 and 9 [U-10]
- Ages 10 & 11 [U-12]



Number Five (5) balls will be used for the Ages 12 &13 [U-14] Group

INDEX

<u>TITLE</u>	<u>PAGE</u>
Acknowledgement Foreword	2
Liability Insurance	3
Program Schedule	4
General Contest Rules	4-5
Five-Goal Contest Rules	6-8
Judges - Five-Goal Contest	9
Five-Goal Goal Specs	10-11
Grid Goal Contest Rules	12-14
Judges – Grid Goal Contest	15
Rope Grid Goal	16
Grid Goal - Goal Specs	17-21
Suggestions	22
 <u>Appendices</u>	
Contestant Score sheet (5-Goal Contest)	A
Contestant Score sheet (Grid Goal Contest)	B
Competition Form - Boys/Girls	C
Contest Event Report	D



- ACKNOWLEDGEMENTS -

The Order and the Elks National Soccer Shoot Program express our sincere gratitude to those visionary Elks and Soccer enthusiasts from Connecticut, New Jersey, Arizona, Wisconsin and elsewhere, who foresaw in this activity a positive and enjoyable way for the Order to benefit young Americans.

- FORWARD -

SOCCKER - The world's favorite sport now is the United States' fastest growing children's participatory activity. As early as the 1980's, Lodges of the B.P.O. Elks began to recognize this phenomenon and support it with league sponsorships as well as developing different skill contests. The Grand Lodge Youth Activities Committee discussed the sport of soccer on many occasions as two of these contests grew to prominent status.

In October 1997, a Grand Lodge Youth Activities Subcommittee met in Chicago to discuss the various programs and to develop a Grand Lodge Program. After a concentrated session, where many viewpoints were expressed and many arguments presented, the Committee agreed upon a two-stage contest that best represented the skill levels of four age groups: 7 and Under (U-8), 8-9 (U-10), 10-11 (U-12), and 12-13 (U-14).

The "Five-Goal Contest" with its succession of smaller target goals lets younger participants (U-8 & U-10) build their confidence as they move down the line. It matches both physical and skill abilities to the challenge they present.

The "Grid Goal Contest" uses the penalty kick distance and an eighteen-inch kickboard height to challenge the older participants (U-12 & U-14) to lift the ball from the field while aiming it for score, thus developing advanced skills.

The Contests are designed for either indoors or outdoors depending on location, weather or climate. Close cooperation with the local soccer associations will insure growth in the participation in this Youth Activity by involving the community with our program.

Finally, remember that the running of all the Youth Activities programs has common goals of keeping children occupied with positive, character-building role models and activities, providing alternatives to drug use, and simply having fun.

Remember:

“SOCCER – IT’S A KICK!”

LIABILITY INSURANCE

What should the Lodge do if the owner of the property where an Elks Soccer Shoot is being held requires proof of Liability Insurance? Call the administrators of the Elks Insurance Programs,

MARSH, INC. at **1-800-421-3557**.

Marsh will issue a Certificate of Liability Insurance that will satisfy the property owner's requirements.

When you contact Marsh, they will first ask for your Lodge number. The purpose is to connect you with the correct Marsh team member.

Marsh, Inc. requires the following information:

- Date of the Soccer Shoot
- Location of the Soccer Shoot Name of the Property Owner
- Name of the Certificate Holder, i.e., School District, City, etc.
- Does the Certificate Holder need to be named as Additional Insured?

The Benevolent and Protective Order of Elks General Liability Policy, issued by National Surety Corporation, provides General Liability Insurance for Elks activities on or away from owned or leased premises. This policy will respond to Bodily Injury and/or Property Damage, subject to the policy terms and conditions.

The Master Liability Insurance Program includes as named insured the Grand Lodge, State Associations (with the exception of major projects) and all Subordinate Lodges of the Order.

The process of issuing a Liability Insurance Certificate is simple, however, Marsh would appreciate your calling at least ten (10) days prior to the event to ensure sufficient Mailing time.

PROGRAM SCHEDULE

Lodge Shoot – _____

District Shoot– _____

State Shoot – _____

Regional Shoot – _____

GENERAL CONTEST RULES

1. There shall be four (4) age groups:
 - **Juniors (FIVE GOAL)** will be comprised of a Boys and a Girls Divisions in each of the following Age Groups:
 - Age 7 and Under [U-8]
 - Age 8 and 9 [U-10]
 - **Seniors (GRID GOAL)** will be comprised of a Boys and a Girls Divisions in each of the following Age Groups:
 - Age 10 and 11 [U-12]
 - Age 12 and 13 [U-14]
2. Age is determined by the age of the Contestants as of August 1st, the year the contest is held.

Age Chart to be supplied on an annual basis

3. The local Lodge Director must verify age by birth or baptismal certificate or by passport to ensure that the contestant competes in the proper age group. This will eliminate any disappointment that might arise as a result of a technical error.
4. A contestant may enter only one local Lodge contest in any given year.
5. The Contest Director will set the date, time and place for the contest, and notify all contestants of the same. Contestants must be present and ready to compete at the designated time.

GENERAL CONTEST RULES CONTINUED

6. Local Lodge contests may be structured in cooperation with local soccer programs so that participants can compete at predetermined times. The time for the local Lodge "finals" if needed, will be posted and those invited to compete in the "finals" must be present and ready to compete at the designated time.
 7. The contest can be held outdoors on a field or indoors in a gym or other suitable area.
 8. No equipment is necessary other than a jersey or shirt, shorts or pants, socks and appropriate footwear (indoor or outdoor). Shinguards and protective gear are not necessary, but may be worn if desired.
 9. No article of clothing that displays words, slogans or images that are in poor taste for a youth athletic activity shall be permitted. The Director's decision in enforcing this rule shall be final.
 10. Any contestants conducting themselves in an inappropriate or unsportsman-like manner or failing to obey the instructions given by the officials will be disqualified.
 11. Contestants who are waiting their turn must not interfere with the contestant who is shooting in any way. All other persons should stay at least ten (10) yards behind the contestant who is shooting. At indoor contests or some outdoor contests where ten (10) yards is not possible, a distance determined by the Director will establish a clearly identified waiting area. No one should be allowed to distract the contestants in any way during the contest. The Director may stop the contest and clear the area if anything interferes with play.
 12. The Director shall have the authority to restrict the number of photographers around the immediate contest area and to restrict where they may position themselves. Flash photography is not permitted at any time while the contest is in progress. The Director may orchestrate a staged photo opportunity where flash photos will be permitted.
 13. The 1st place winners at each level of contest are eligible to advance to the next level. If the 1st place winner in any age group is unable to attend, the next highest scorer shall be eligible.
 14. ALL DECISIONS BY THE DIRECTOR AND CONTEST OFFICIALS ARE FINAL AND NO SPECTATOR OR OTHER PERSON WILL BE PERMITTED TO ARGUE OR INFLUENCE AN OFFICIALS DECISION IN ANY WAY.
- **Contest Tabulators - TWO or THREE:**
The competition Director will appoint two or three volunteers to tabulate all Soccer Shoot[®] Registration and Score Sheets. They will make sure each form is filled out correctly and then tabulate the scores to filed out the winners. They will post the winners in each division for boys and girls. The Tabulators will also produce for the Soccer Shoot[®] Director a list of the winners for each division. No scores will be given out to competitors until the competition is over.

FIVE GOAL

CONTEST

5-GOAL CONTEST RULES

Ages 7 & Under [U-8] and Ages 8 & 9 [U-10]

1. Contestants may only shoot for score once unless involved in a tiebreaker.
2. No contestant may shoot before or after the designated time. Disqualification will result.
3. The order of shooting will be determined by a drawing, after all are properly registered. Only Lodge Shoots may have the option of customizing the shooting order according to local conditions.

4. The goals and scores are as follows:

48 inch goal	1 point per successful goal
40 inch goal	2 points per successful goal
34 inch goal	3 points per successful goal
26 inch goal	4 points per successful goal
17 inch goal	5 points per successful goal

5. A goal is scored when the whole of the ball has passed over the entire goal line, between the goal posts at-id below the upper crossbar. The decision of the judges is final.
6. The soccer ball will be a FIFA approved, Number Four-(4) ball, inflated between 8.5 to 10 lbs. pressure at the start of the contest.
7. There shall be one goal judge, one line judge, and one scoring judge per contestant shooting.
8. There shall also be thee tabulators, who are located in a secure area. The tabulators shall calculate the official score.
9. Contestants will start at the 48" goal and will advance to each successive smaller goal. When a contestant reaches the third goal the next contestant may begin.
10. The line judge will place the ball on a line fifteen (15) feet from the goal line for 7 and Under (U-8) contestants. The 8 and 9 (U-10) contestants will kick front a tine eighteen (18) feet from the goal line. The contestant may adjust the ball along the foul line by using the foot only. The Line judge will confirm that the ball is still legally placed. The ball shall be deemed in play as soon as it is kicked forward and cannot be kicked a second time.
11. Each contestant will be permitted one (1) warm-up kick at each goat. They will then kick three (3) shots for score at each of the five different sized goals in sequence from 48" down to the 17" goal. The contest officials will notify each contestant when scoring begins. Forty-five (45) points is possible.
12. Taking five (5) additional shots in the same contestant order as the regular contest will break ties. The 17" goal will be used. If still tied, this procedure will be repeated until award winners are decided.

5-Goal Goal Set-up

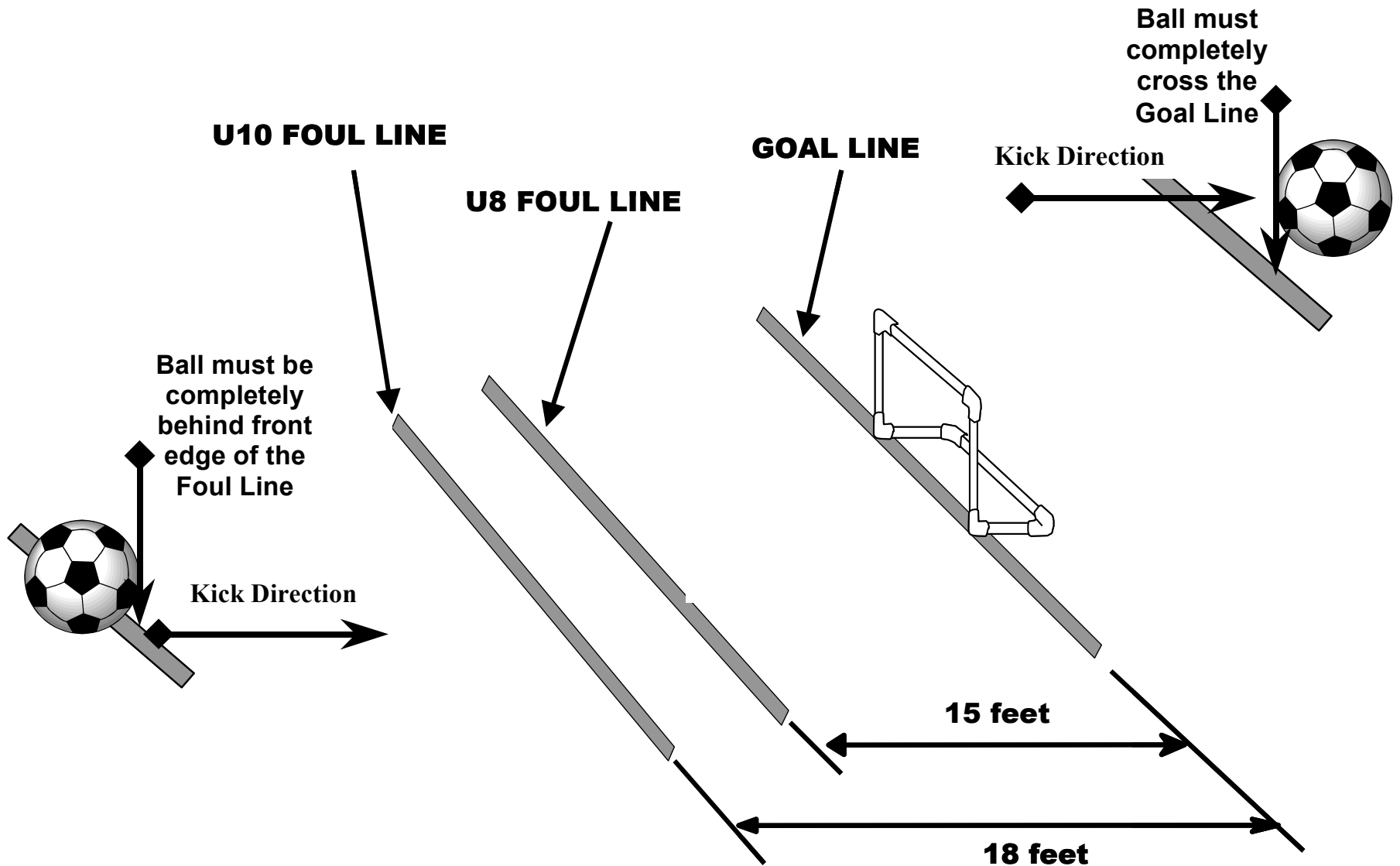

5-GOAL CONTEST RULES (CONTINUED)

OFFICIALS / JUDGES - 5-GOAL CONTEST

Volunteers will be needed for the following:

○ **Goal judges - TWO:**

The Goal judges will indicate a goal by raising their hands above their head after the ball completely crosses the goal line or indicate a missed goal by pointing at the grout-id.

○ **Line judge - ONE:**

The Line judge will determine that the ball was kicked from a location completely behind the foul line. The Line judge will notify each competitor prior to their last shot in each set that this is the last shot.

○ **Scoring judges - ONE to THREE:**

The Scoring judge(s) will maintain the Contestant Registration Form and Score Sheet for all contestants that they are responsible for. The Scoring judge(s) will move from goal to goal with the contestant. The Scoring judge(s) will mark goal attempts with either an X for a successful goal or a dash for all unsuccessful goal, only after the Line judge has indicated if the attempt was successful or unsuccessful. The Scoring judge(s) should not tabulate the competitors' scores. Upon completion of an individual's competition, the score shall be turned over the Tabulators.

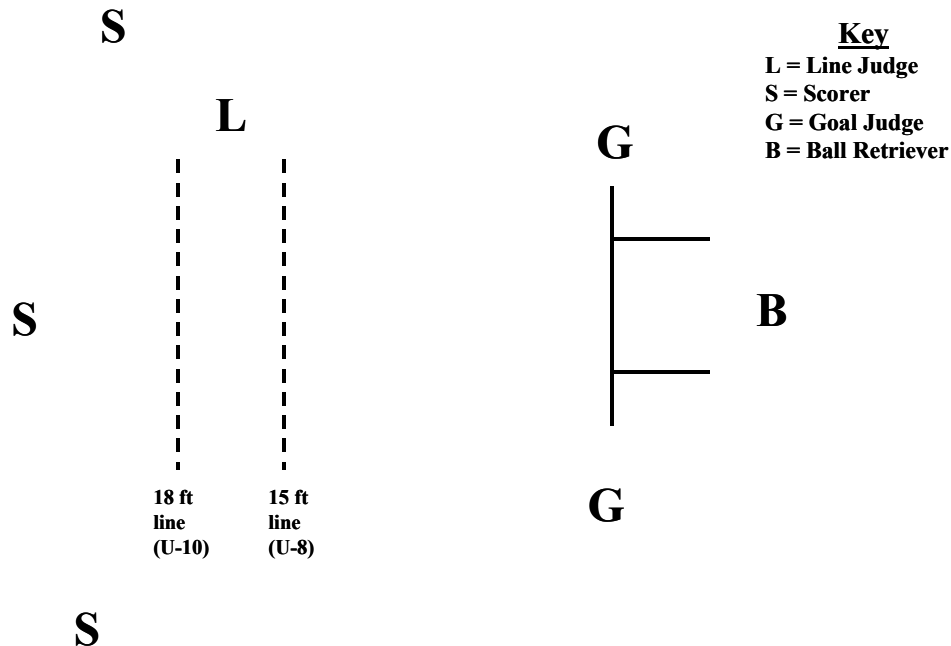

- In order to expedite the contest, it is recommended that a minimum set of five goals be used for competitions.
- A goal line should, be laid down and each goal should be placed on the goal line. Each goal should be a minimum of 4 feet apart. A forty foot-square area is the minimum area that you can work in.

Ground View of 5-Goal Soccer Shoot[®] Goal

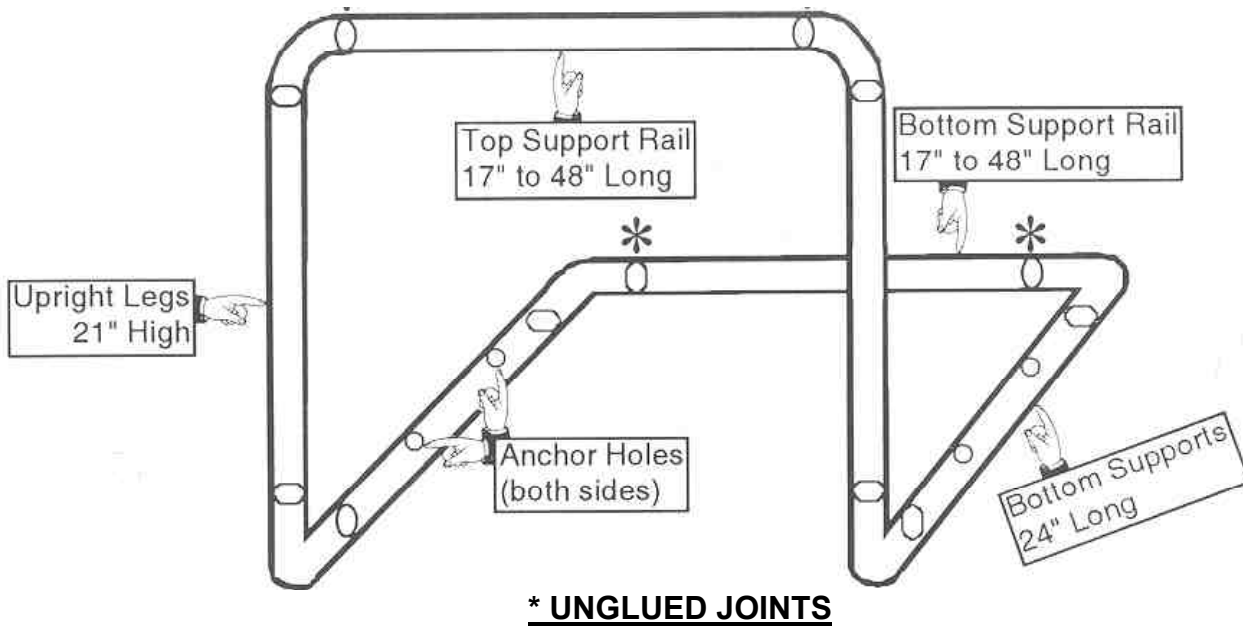

Free-Standing Goal Parts List:

Quan	Description
2	48" top & bottom rails
2	40" top & bottom rails
2	34" top & bottom rails
2	26" top & bottom rails
2	17" top & bottom rails
10	21" upright legs.
10	24" bottom supports
30	90-degree elbows
20	anchors (spikes/tent pegs)
	PVC Pipe Glue
(See also Alternate Goal Equipment Attachment for standard Soccer Goal on following pages.)	

Each goal should be constructed using 1 ½ -inch (ID) Heavy Duty Schedule 40-PVC Tubing and Elbows. This size provides adequate strength and allows for flexibility. You will need 65 feet of the PVC pipe for 5 goals. All corners use 90-degree Elbows. Drill holes in the bottom supports large enough to accommodate the spikes so the goal can be firmly anchored to prevent movement or overturning. The pieces will fit together quite snugly. However, you may wish to glue a few of the connections for added stability* Leaving some of the couplings unglued allows for size changes and for easy takedown, transport and storage.

Alternate method of fabricating a Small Goal

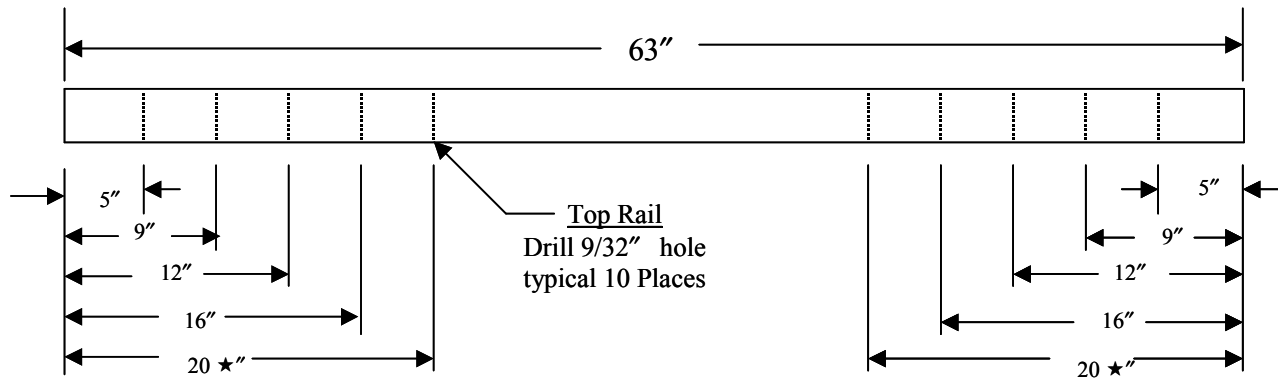

Goal openings between uprights will be 48", 40", 34", 26" and 17".

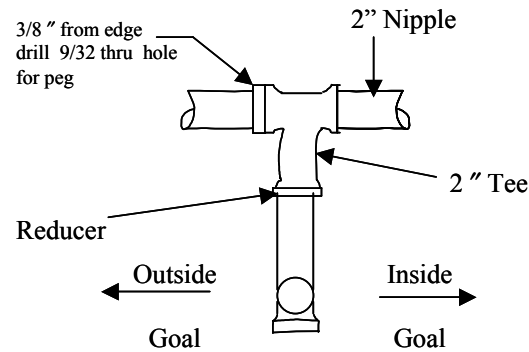
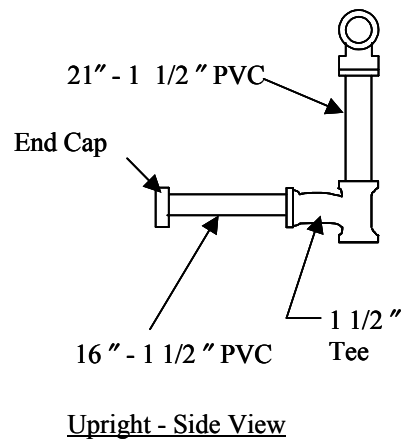

Upright - Rear View (left side)

COMPONENTS

Top Rail

- a. (1) 63" - 1 1/2" PVC
- b. (2) 1 1/2" PVC End Caps
- c. (2) 5" - 1" x 4" Pegs ("L" shape)

Uprights

- a. (2) 21" - 1 1/2" PVC
- b. (2) 16" - 1 1/2" PVC
- c. (2) 2" PVC Tees
- d. (2) 2" x 1 1/2" male reducers
- e. (2) 1 1/2" PVC Tees
- f. (2) 1 1/2" End Caps
- g. (4) 3 1/2" - 2" PVC Nipples
- h. Plumbers Glue

GRID GOAL

CONTEST

GRID GOAL CONTEST RULES

Ages 10 & 11 [U-12] and Ages 12 &13 [U-14]

1. Contestants may only shoot for score once, unless involved in a tiebreaker.
2. No contestant may shoot before or after the designated time. Disqualification will result.
3. The order of shooting will be determined by a drawing after all contestants are properly registered. Lodge Shoots may have the option to customize the shooting order according to local conditions.

4. The goals and scores are as follows:

- a. Across Bottom 1 point per successful shot
- b. Middle Center 2 points per successful shot
- c. Middle Ends 3 points per successful shot
- d. Top Center 4 points per successful shot
- e. Top Ends 5 points per successful shot

Goal

5	4	5
3	2	3
1	1	1

5. A goal is scored when the whole of the ball has passed through the entire grid opening. If the ball hits a grid post and enters the net, the kick is good. If the ball hits a grid post or bottom barrier and bounces back from the grid opening, it is a missed ball. The decision of the judges is final.

6. The soccer ball used will be an FIFA approved ball:
7. Ages 10 & 11 [U-12] will use a Number Four (4) ball
8. Ages 12 &13 [U-14] will use a Number Five (5) ball,
9. Balls are to inflated to 8.5 to 10 tbs. pressure at the start of the contest.

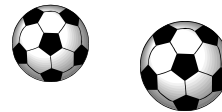

10. There shall be two Goal judges, one Line judge and one to three Scoring judges.
11. The Line judge will place the ball on a spot thirty-six (36) feet from the goal line and centered on the goal. (Equivalent to a penalty kick location defined by FIFA). The ball shall be deemed in play as soon as it is kicked forward and can not be kicked a second time. During Lodge and District competition, should the penalty kick spot become worn, adjustments can be made, but no closer to the goal.
12. Each contestant will be permitted three (3) warm-up kicks at the grid. They will then kick fifteen (15) goals for score. The contest officials will notify each contestant when scoring begins. A maximum seventy-five (75) points is possible.
13. Taking five (5) additional shots in the same order as the regular contest will break ties. If still tied, this procedure will be repeated until award winners are decided.

Grid Goal Set-up

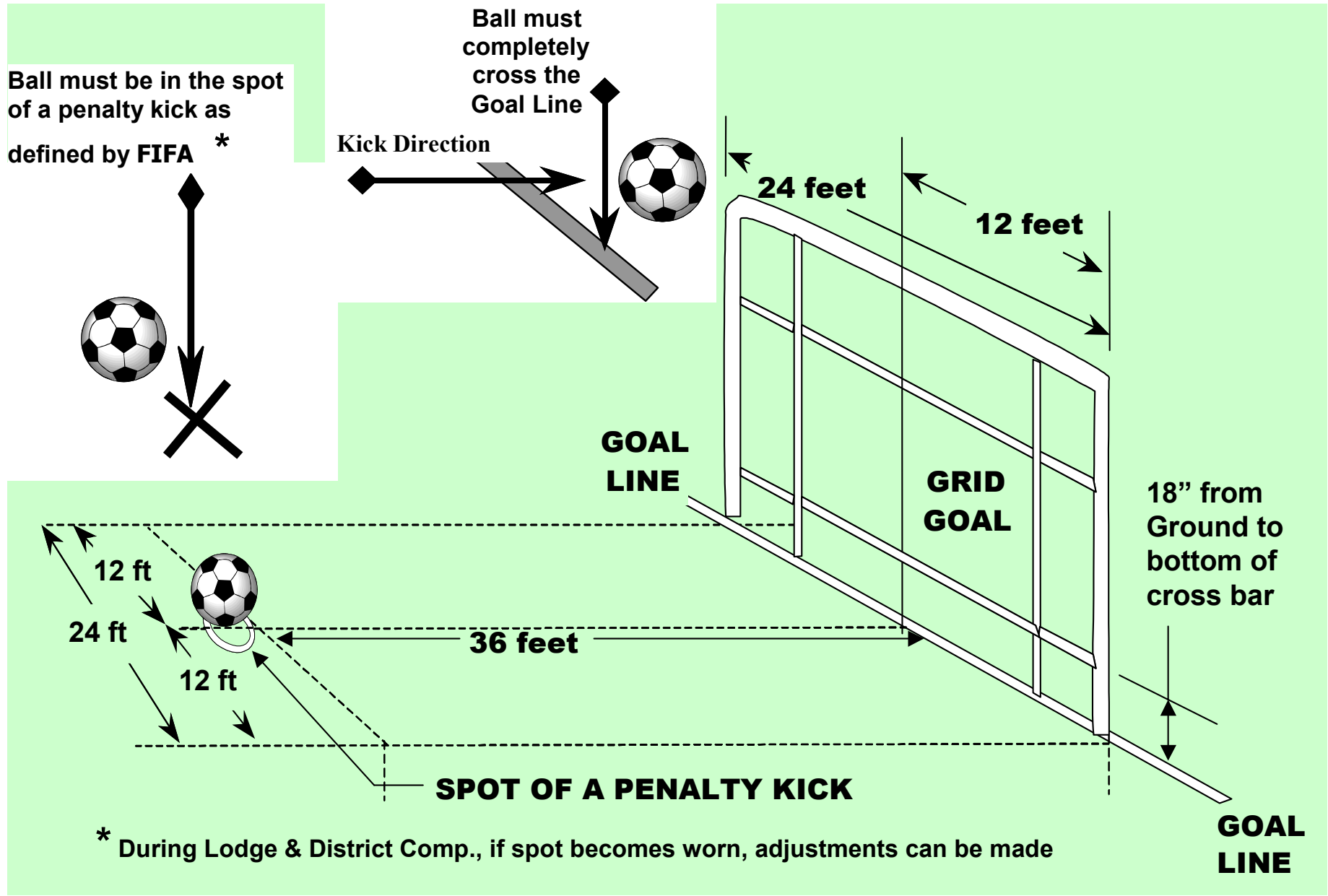

Ball must be in the spot of a penalty kick as defined by FIFA *

Ball must completely cross the Goal Line

Kick Direction

24 feet

12 feet

GOAL LINE

GRID GOAL

18" from Ground to bottom of cross bar

12 ft

24 ft

12 ft

36 feet

SPOT OF A PENALTY KICK

* During Lodge & District Comp., if spot becomes worn, adjustments can be made

GOAL LINE

OFFICIALS / JUDGES - GRID GOAL CONTEST

Volunteers will be needed for the following:

- **Ball Retrievers - TWO:** The Ball Retrievers will control all balls that miss the goal and return all balls to the Line judge after the contestant has completed the round of kicks.
- **Goal judges - TWO:** The Goal Judges will take up positions at opposite sides of the Grid Goal and immediately after the kick has been completed advise the Scoring judge(s) of the Point Value earned for that kick. If necessary, the Goal judges may confer before announcing the point value so as to reach a unanimous decision in the event of a kick whose path is not clearly seen by one of the judges.
- **Line Judge - ONE:** The Line judge will determine that the ball was kicked from the penalty point. If the ball roll off the penalty point before the kicker advances toward the ball, the Line judge will re-set the ball on the penalty point. If the kicker kicks the ball, it is a counted kick.
- **Scoring judges - ONE to THREE:** The Scoring judge(s) will maintain the Contestant Registration and Score Sheets for all contestants that they are responsible for. The Scoring judge(s) will mark goal attempts with the goal value for each kick taken. The Scoring judge(s) will tabulate the competitor's individual shots. They will insure that each form is filled out correctly and attest to the shot scores. They may tabulate the scores to establish the winners however separate Tabulator(s) are recommended.

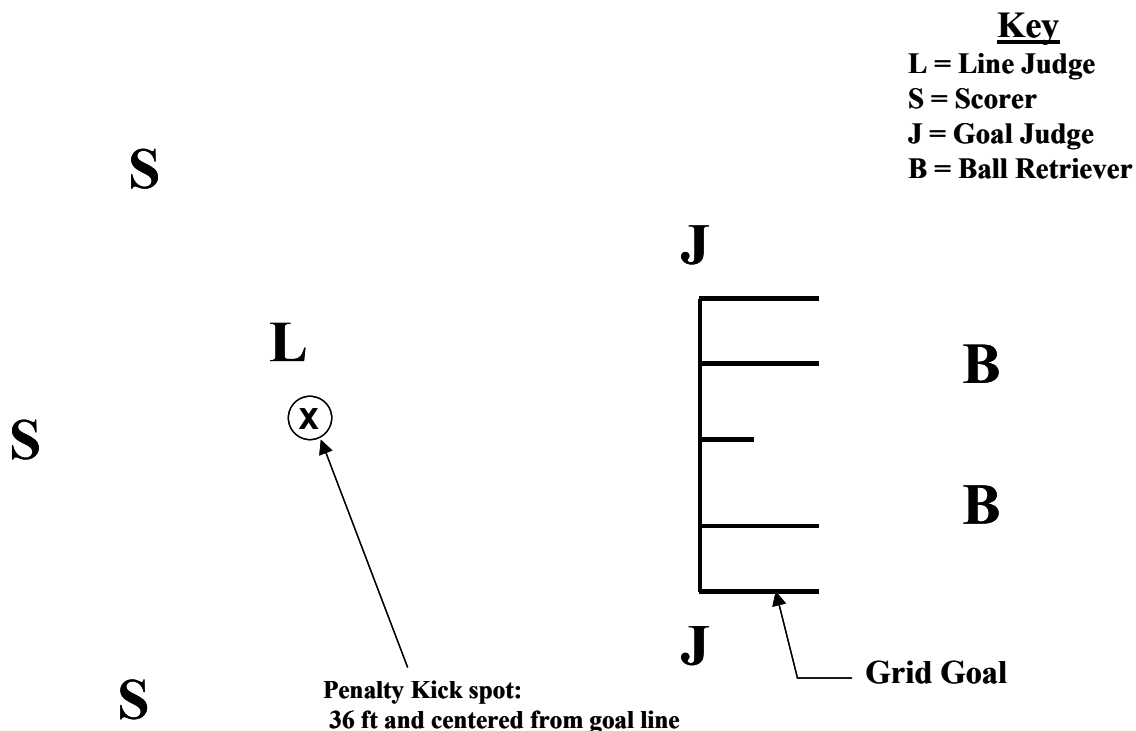

GOAL SPECIFICATIONS

ROPE GRID GOAL

A grid goal made from rope is an economical arrangement that has accepted for the Elks Soccer Shoot® Lodge and District level competitions.

Obtain the following parts:

Quan	Description	Quan	Description
75 feet	Yellow 3/8-inch rope	6	Hooks with Eyelet attached
2	10- or 12-inch Turnbuckles for the horizontal sections	2	Weights (for the bottom of the parallel ropes, will help keep the rope straight)

Total Estimated Cost = \$40-00

Wrap the hooks around the goal pole at the sides at-id tighten turnbuckles. Swing the vertical rope over the top goal bar and hook. Attach weights at lower ends of vertical ropes.

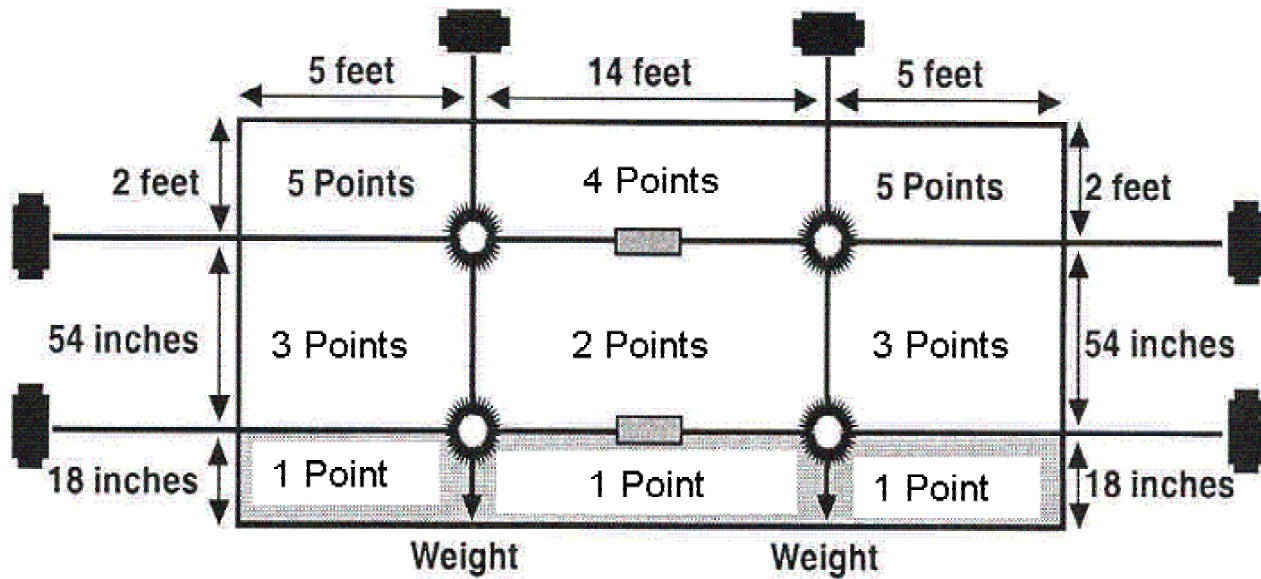

 Turnbuckle

 Hook & Eyelet

 Twist Ties

GRID GOAL SPECIFICATIONS

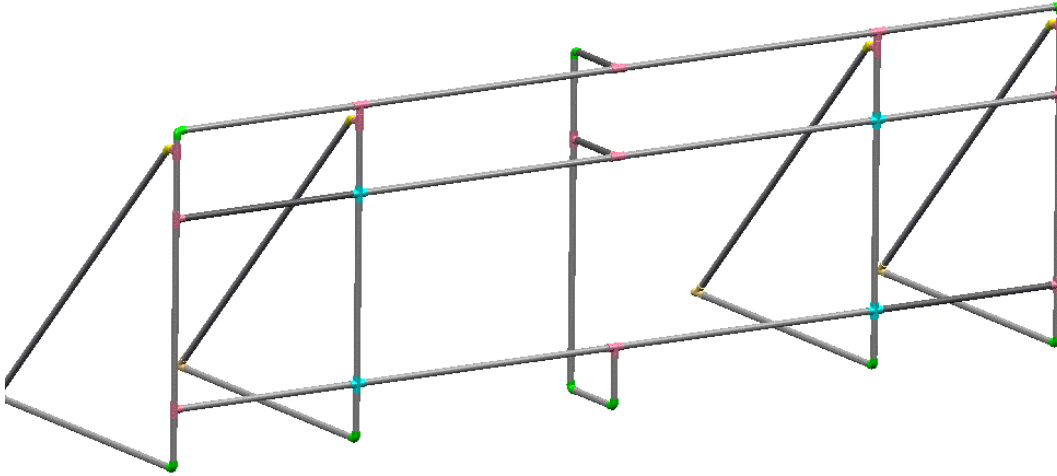

Parts Chart

Item	Qty	Description/Length	Specifics
Piping	<i>Use 1 1/2 Bristol Pie PVC 330 PSI</i>		
A	2	4 ft - 8 7/8 in	
B	2	6 ft - 9 1/4 in	
C	4	4 ft - 8 3/4 in	
D	4	6 ft - 9 in	
E	2	1 ft - 6 1/8 in	
F	2	1 ft - 6 1/4 in	
G	4	4 ft - 3 7/8 in	
H	4	7 ft - 4 1/2 in	
I	4	10 ft - 3 in	
J	1	1 ft - 8 5/8 in	painted black
K	1	1 ft - 8 3/4 in	painted black
L	1	1 ft - 8 7/8 in	painted black
M	1	5 ft - 8 7/8 in	painted black
N	1	1 ft - 8 1/2 in	painted black
O	1	1 ft - 3 7/8 in	
P	8	2 in	inserts
R	5	15 in	will need to trim to fit to obtain 18" clearance
Fittings	<i>Use 1 1/2 in type fittings</i>		
1	4	4-Way "T"	
2	14	3-Way "T"	
3	8	90 - degree elbow	

GRID GOAL SPECIFICATIONS

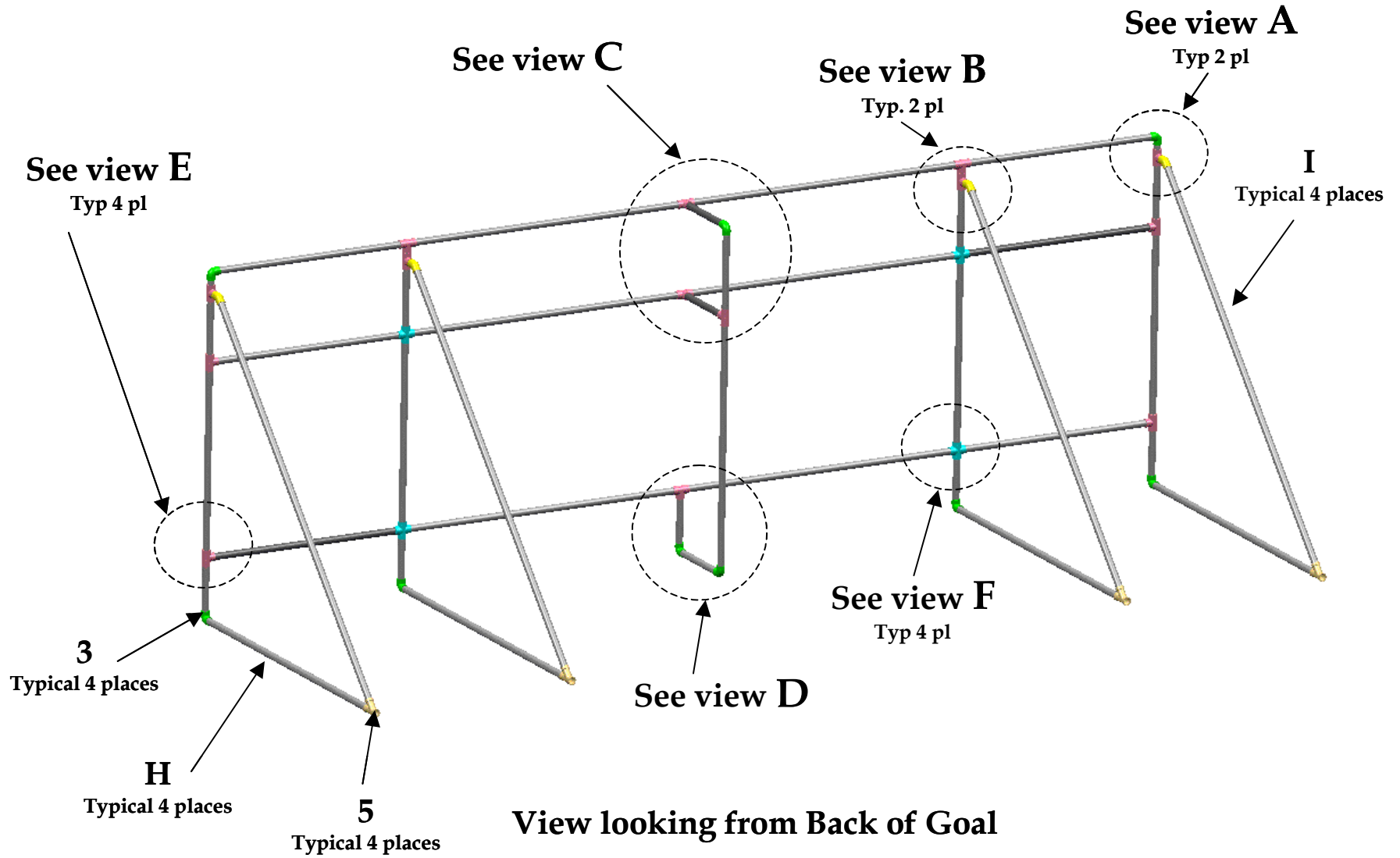

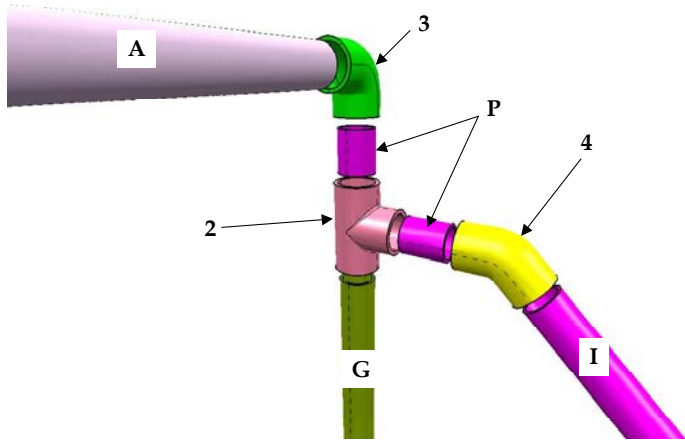

View A
Upper Corner
typical 2 places

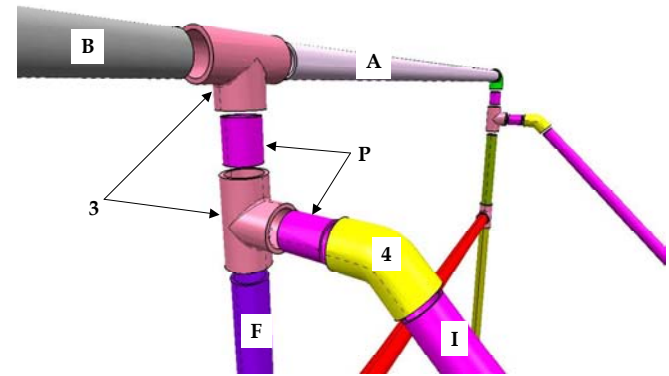

View B
Upper Interior Connections
typical 2 places

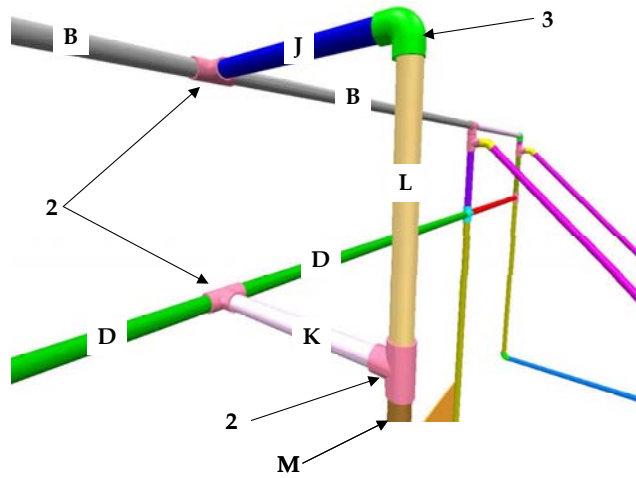

View C
Upper Center Post
Looking from back of Goal

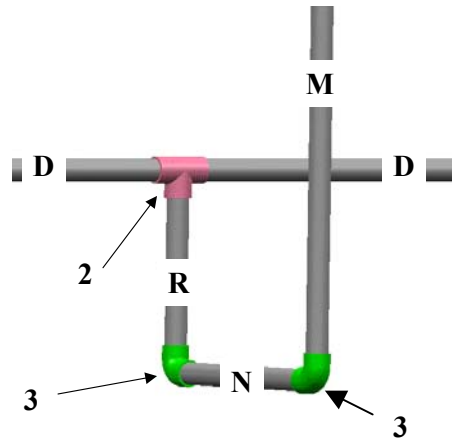

View D
Lower Center Post
 Looking from back of Goal

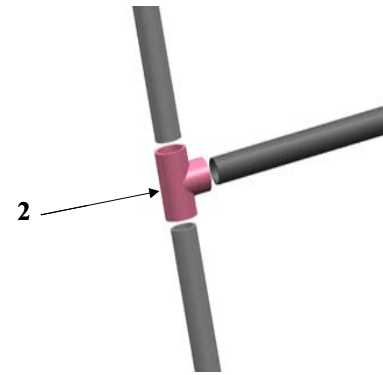

View E
3 - Way " T " Connections
 Typical 4 places

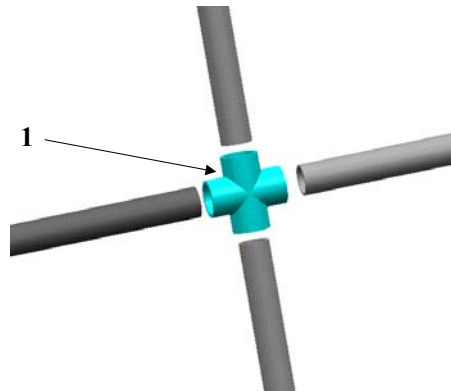

View F
4 - Way " T " Connections
 Typical 4 places

SUGGESTIONS:

COMPETITION LOGISTICS

FIVE GOAL COMPETITION:

- **BALLS** - Ideally, a minimum of three (3) balls should be used and all three kicks should be taken before any balls are returned to the shooter. This will save time and shorten the waiting time before the next contestant's attempt.
- **GOALS** - In order to expedite the contest, it is recommended that a minimum set of five goals be used for competitions.
- **FIELD LAYOUT** - Goal and Foul Lines should, be laid down.
 - Each goal should be a minimum of 4 feet apart. A forty foot-square area is the minimum area that you should work within.

GRID GOAL COMPETITION:

- **BALLS** - It is suggested that fifteen (15) balls be on hand to run the contest smoothly. This allows for the contestants to kick at their own rhythm without interference from returning balls.

Field

LAWN MOWER AND RAKE:

It is recommended that the Soccer Shoot' area be mowed and raked prior to the Contest. Generally, the Soccer Shoot' is held on the side of a field and the grounds care may not be as smooth as the playing field.

FOUL LINE MARKING:

The foul line is best marked with a product similar to the spray paint that is used to mark utility lines in the grass or black top, i.e., Power Paint Cartridge. Fluorescent colors work-best. If such a product is unavailable, fluorescent tape such as that used in construction also works.

ADDITIONAL EQUIPMENT

- Pressure Gauge, Inflation Needle & Pump
- 50 foot measuring tape
- Tables, chairs
- A separate bleacher / sitting area for spectators is recommended.

Press Releases:

A large part of the Soccer Shoot[®] program is to permit the kids to have fun. As such, it is necessary to let the community know that the Elks Soccer Shoot' exists. Press Releases and Purchased Advertising (samples available from your Regional Director) will permit your Lodge not only to hold a successful Soccer Shoot' but to share your news with the community.

APPENDIX



Elks Soccer Shoot[®]



Contestant Score Sheet: 5 - Goal Contest: U-8 & U-10

Event Location:	Date:
------------------------	--------------

(Circle One In each category)

BOYS			GIRLS		
Lodge	District	State	Regional	National	

<u>Division</u>	
7 & Under (U-8)	8 - 9 (U-10)

Name: _____
Telephone No.: _____

<u>Age as of August 1</u>

CONTESTANT: DO NOT WRITE BELOW THIS LINE (For Official Use Only!)

Goal No. 1- 48 inch width	(x for each shot made)	(- for each shot missed)	
SHOT 1)	SHOT 2)	SHOT 3)	
Goal No. 2- 40 inch width	(x for each shot made)	(- for each shot missed)	
SHOT 1)	SHOT 2)	SHOT 3)	
Goal No. 3- 34 inch width	(x for each shot made)	(- for each shot missed)	
SHOT 1)	SHOT 2)	SHOT 3)	
Goal No. 4- 26 inch width	(x for each shot made)	(- for each shot missed)	
SHOT 1)	SHOT 2)	SHOT 3)	
Goal No. 5- 17 inch width	(x for each shot made)	(- for each shot missed)	
SHOT 1)	SHOT 2)	SHOT 3)	

Total Goals	x 1 =	Goal #1 Score
Total Goals	x 2 =	Goal #2 Score
Total Goals	x 3 =	Goal #3 Score
Total Goals	x 4 =	Goal #4 Score
Total Goals	x 5 =	Goal #5 Score

SCORE

Tie Breaker

(17-inch Goal Only) (x for each shot made) (- for each shot missed)

1	2	3	4	5	Total Goals

1	2	3	4	5	Total Goals

1	2	3	4	5	Total Goals

1	2	3	4	5	Total Goals

1	2	3	4	5	Total Goals

1	2	3	4	5	Total Goals



Elks Soccer Shoot[®]



Contestant Score Sheet: Grid Goal Contest: U-12 & U-14

Event Location:	Date:
-----------------	-------

(Circle One In each category)

BOYS			GIRLS	
Lodge	District	State	Regional	National

<u>Division</u>	
10 & 11 (U-12)	12 & 13 (U-14)

Name: _____
Telephone No.: _____

<u>Age as of August 1</u>

CONTESTANT: DO NOT WRITE BELOW THIS LINE (For Official Use Only!)

<i>Indicate Actual Number of Points Scored for Each Shot</i>		
SHOT 1) _____	SHOT 6) _____	SHOT 11) _____
SHOT 2) _____	SHOT 7) _____	SHOT 12) _____
SHOT 3) _____	SHOT 8) _____	SHOT 13) _____
SHOT 4) _____	SHOT 9) _____	SHOT 14) _____
SHOT 5) _____	SHOT 10) _____	SHOT 15) _____

SCORE

--

Tie Breaker Section

(Indicate Actual Point scored for each shot)

1	2	3	4	5	Total

1	2	3	4	5	Total

1	2	3	4	5	Total

1	2	3	4	5	Total

1	2	3	4	5	Total

1	2	3	4	5	Total



Elks Soccer Shoot[®]



COMPETITION FORM –BOYS / GIRLS:

Please let us know who will compete as your representative at the next level
Complete and return not later than 5 days after your Elks Soccer Shoot[®] contest to the
Director of the next level of competition:

This is the information needed to adequately prepare for the next level of competition

Sponsoring Lodge:	No:
-------------------	-----

<i>(Circle One In each category)</i>			
GENDER GROUP		NEXT LEVEL OF COMPETITION	
BOYS	GIRLS	District	State
		Regional	National

Division U- 8	Ages 7 & Under			Total Number of Participants and Guests Attending Next Competition
Name:		Date of Birth:		
Address:		Telephone:		
City:	State:	ZIP:		
Parent Name:				

Division U- 10	Ages 8 & 9			Total Number of Participants and Guests Attending Next Competition
Name:		Date of Birth:		
Address:		Telephone:		
City:	State:	ZIP:		
Parent Name:				

Division U- 12	Ages 10 & 11			Total Number of Participants and Guests Attending Next Competition
Name:		Date of Birth:		
Address:		Telephone:		
City:	State:	ZIP:		
Parent Name:				

Division U- 14	Ages 12 & 13			Total Number of Participants and Guests Attending Next Competition
Name:		Date of Birth:		
Address:		Telephone:		
City:	State:	ZIP:		
Parent Name:				



Elks Soccer Shoot[®]

CONTEST EVENT REPORT

No later than 5 days after your Elks Soccer Shoot[®] contest has taken place, complete this Contest Event Report and two **COMPETITION FORMS** (for **BOY** and **GIRL WINNERS**) and forward to the Director of the next level of competition

COMPETITION DATE				
Report for	LODGE	DISTRICT	STATE	REGIONAL
	<i>(Circle One)</i>			

Lodge District State:	No.
Competition Director:	Telephone:
Address:	City: State ZIP
Competition Location:	

Attendance:
This information is vital to the Program's future Please Report Completely

Parents & Family	Additional Spectators		Volunteers		Contestants								
	Elks	Non-Elks	Elks	Non-Elks	U-8		U-10		U-12		U-14		
					Girls	Boys	Girls	Boys	Girls	Boys	Girls	Boys	

Description	Total Expenses	Total Contributions	Total Income	
Competition				Elk volunteer hours
Advertising / Costs				Non Elk volunteer hours
Awards / Prizes / Certificates				Elk volunteer miles
Lodging				Non Elk volunteer miles
Meals / Snacks etc.				Attach additional support as required
Admin-supplies, copies, postage etc.				
Miscellaneous				
Total				